

Model:
TUC-93D-2-HC

Deep Undercounter:
Drawered Refrigerator with Hydrocarbon Refrigerant

TUC-93D-2-HC

- ▶ True's undercounter units are designed with enduring quality that protects your long term investment.
- ▶ Factory engineered system using environmentally friendly R290 hydro carbon refrigerant maintains temperature of 0.5°C to 3.3°C for the best in food preservation.
- ▶ Exterior - stainless steel front, top and ends. GalFan coated steel back.
- ▶ Interior - NSF approved, clear coated aluminum liner. Stainless steel floor with coved corners.
- ▶ Each drawer accommodates one (1) 2/1GN (W 650mm x D 530 x H 200 mm) food pan (sold separately).
- ▶ Foamed-in-place using a high density, environmentally friendly polyurethane insulation.



NOTE: Door or drawer assemblies can be located in any section of the cabinet. Location of doors/drawers must be indicated at time of ordering.

PLAN VIEW

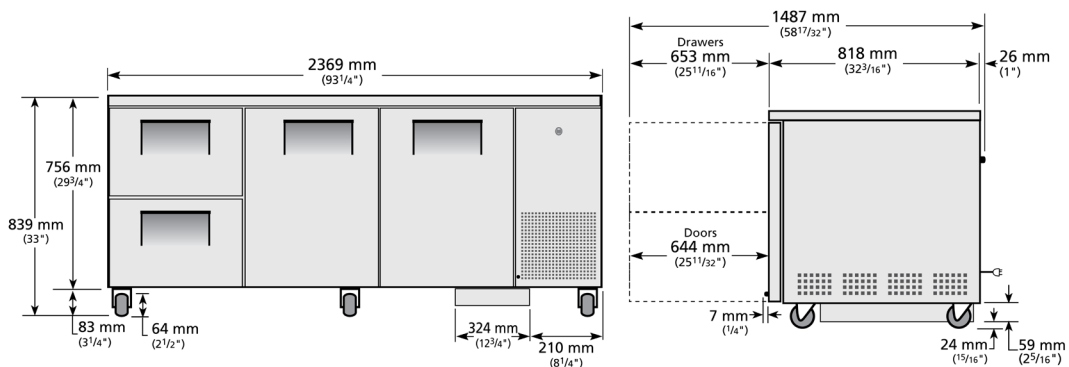

ROUGH-IN DATA

Voltage: 220-240V/50Hz

Specifications subject to change without notice. Chart dimensions rounded up to the next whole millimeter (inches rounded up to the next 1/8").

Model	Model Type	Doors/Drawers	Shelves	Cabinet Dimensions (mm)			Net Volumes (litres)	EEC	EEI	24 hr/ Energy Consumption (kWh)	Annual Energy Consumption (kWh)	Crated Weight (kg)
				W	D †	H						
TUC-93D-2-HC	Counter Chilled	2/2	4	2373	822	839	—	B	30,7	3,14	1146	261

† Depth does not include 26 mm for rear bumpers.
Test Standard: EN16825 - Climate Class 5 (40°C, 40% relative humidity).